



LUMINAIRE TESTING LABORATORY, INC.

SUSTAINING
MEMBER
of the
IESNA

905 Harrison Street · Allentown, PA 18103 · 610-770-1044 · Fax 610-770-8912 · www.LuminaireTesting.com

LTL NUMBER: 13196

DATE: 09-12-2008

PREPARED FOR: EB FLUORESCENT COMPANY, INC.

CATALOG NUMBER: TCH 2/54

LUMINAIRE: FORMED WHITE ENAMEL STEEL HOUSING/REFLECTOR, NO ENCLOSURE.

LAMPS: TWO 54 WATT T5 HIGH OUTPUT LINEAR FLUORESCENT LAMPS RATED AT 4400 LUMENS EACH.

LAMP CATALOG NUMBER: PHILIPS F54T5/841/HO/ALTO

BALLAST: ONE KEYSTONE TECHNOLOGIES KTEB-254HO-UV-TP-PS/LS

MOUNTING: SURFACE/PENDANT

NOTE: THIS TEST REPORT WAS PRORATED TO A FOUR LAMP, EIGHT FOOT

LUMINAIRE TEST USING MEASURED DATA FROM LTL TEST NUMBER 13195.

TOTAL AS TESTED INPUT WATTS =120.9 AT 120.0 VOLTS

TOTAL PRORATED INPUT WATTS = 241.8 AT 120.0 VOLTS

THE 0 DEGREE PLANE IS PARALLEL WITH THE LAMPS.

#13196

CANDELA DISTRIBUTION

	0.0	22.5	45.0	67.5	90.0
0	3483	3483	3483	3483	3483
5	3451	3474	3480	3497	3506
15	3328	3381	3446	3523	3555
25	3085	3190	3367	3498	3548
35	2733	2917	3174	3424	3522
45	2290	2559	2960	3326	3459
55	1769	2129	2701	3102	3249
65	1192	1697	2300	2866	3054
75	597	1165	1996	2520	2723
85	99	740	1237	1574	1695
90	0	356	785	1119	1239
95	0	573	1178	1525	1643
105	0	393	802	1568	1889
115	0	182	849	1113	1209
125	0	0	566	1049	1199
135	0	0	196	590	741
145	0	0	0	133	234
155	0	0	0	0	0
165	0	0	0	0	0
175	0	0	0	0	0
180	0	0	0	0	0

FLUX

332
976
1544
1983
2265
2337
2228
1945
1215
1077
995
677
493
227
43
0
0
0
0
0

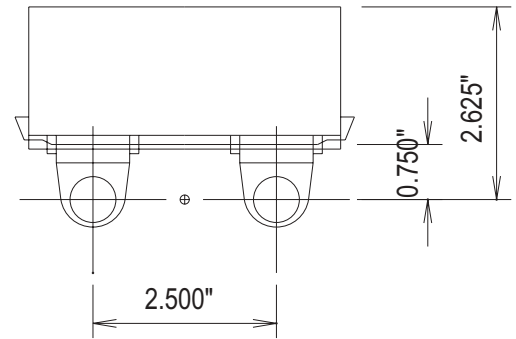

ZONAL LUMEN SUMMARY

ZONE	LUMENS	%LAMP	%FIXT
0- 30	2853	16.2	15.6
0- 40	4835	27.5	26.4
0- 60	9437	53.6	51.5
0- 90	14825	84.2	80.9
90-120	2749	15.6	15.0
90-130	3242	18.4	17.7
90-150	3511	19.9	19.1
90-180	3511	19.9	19.1
0-180	18337	104.2	100.0

TOTAL LUMINAIRE EFFICIENCY: 104.2%

TOTAL REFLECTANCE OF PAINT: 81.6%

CIE TYPE: SEMI-DIRECT

PLANE: 0-DEG 90-DEG

SPACING CRITERIA: 1.2 1.5

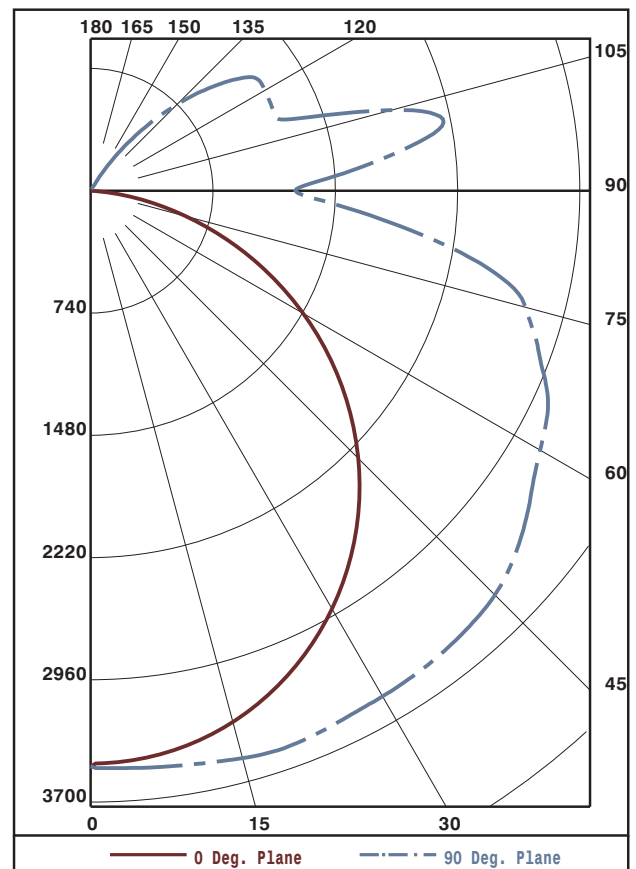

Approved By: MG

THIS REPORT BASED ON LM-41 AND OTHER PERTINENT IESNA PROCEDURES.



LUMINAIRE TESTING LABORATORY, INC.

SUSTAINING MEMBER of the IESNA

905 Harrison Street · Allentown, PA 18103 · 610-770-1044 · Fax 610-770-8912 · www.LuminaireTesting.com

LTL NUMBER: 13196

DATE: 09-12-2008

PREPARED FOR: EB FLUORESCENT COMPANY, INC.

COEFFICIENTS OF UTILIZATION - ZONAL CAVITY METHOD
EFFECTIVE FLOOR CAVITY REFLECTANCE 0.20

Table with 14 columns (RC, RW, 80, 70, 50, 30, 10, 0) and 11 rows (0-10) showing utilization coefficients.

PLANE: 0-DEG 90-DEG
LUMINOUS LENGTH: 96.000 4.500
HEIGHT OF SIDE: 0.000 1.125

Table with 4 columns (ANGLE IN DEG, AVERAGE 0-DEG, AVERAGE 45-DEG, AVERAGE 90-DEG) and 6 rows (0, 45, 55, 65, 75, 85) showing luminance values.



LUMINAIRE TESTING LABORATORY, INC.

SUSTAINING MEMBER of the IESNA

905 Harrison Street · Allentown, PA 18103 · 610-770-1044 · Fax 610-770-8912 · www.LuminaireTesting.com

LTL NUMBER: 13196
PREPARED FOR: EB FLUORESCENT COMPANY, INC.

DATE: 09-12-2008

CANDELA DISTRIBUTION

Table with 6 columns of candela values for various angles from 0 to 180 degrees.

ZONAL LUMEN SUMMARY

Table with 3 columns showing lumen values for various zones from 0-5 to 175-180 degrees.

THIS TEST WAS CONDUCTED USING RELATIVE PHOTOMETRY TECHNIQUES ACCORDING TO STANDARD IESNA PROCEDURES. THE USER MUST THEREFORE USE CAUTION IN THE FOLLOWING SITUATIONS: 1) THIS TEST WAS PERFORMED USING A SPECIFIC BALLAST/LAMP COMBINATION. EXTRAPOLATION OF THESE DATA FOR OTHER BALLAST/LAMP COMBINATIONS MAY PRODUCE ERRONEOUS RESULTS. 2) ACCORDING TO IESNA PROCEDURES, THE BALLAST(S) AND LAMP(S) ARE PRESUMED TO PRODUCE 100% OF RATED OUTPUT. AN APPROPRIATE BALLAST FACTOR MUST BE APPLIED TO THE LUMEN OUTPUT RATINGS AND LUMINOUS INTENSITY VALUES GIVEN. 3) THIS TEST WAS CONDUCTED IN A CONTROLLED LABORATORY ENVIRONMENT WHERE THE AMBIENT TEMPERATURE WAS HELD AT 25°C ±1°C. FIELD PERFORMANCE MAY DIFFER PARTICULARLY IN REGARDS TO CHANGE IN LUMINOUS OUTPUT AS A RESULT OF DIFFERENCE IN AMBIENT TEMPERATURE AND METHOD OF MOUNTING THE LUMINAIRE.



A Notice About Extremely High Efficiencies and Efficiencies Exceeding 100%

Preface

All fluorescent lamps exhibit some change in lumen output as a function of ambient temperature. Highly loaded lamps such as T5 high output, twin tube fluorescent, and high-wattage compact fluorescent lamps typically exhibit the most dramatic light output versus temperature curves. These curves are non-linear functions that have a peak light output at a temperature near the middle of the lamp's usable temperature range. See Figure 1 for the temperature response of a typical T5 high output lamp. The specific temperature where the peak lumen output occurs is dependent on many variables within the lamp manufacturing process as well as the lamp orientation within the luminaire (base up, base down, horizontal).

In the case of T5 high output lamps, the peak lumen output temperature falls near the 35°C(95°F) temperature.

What does this have to do with testing?

You might be wondering, "Since IESNA standards on fluorescent testing are based on relative photometry, what effect does this have on my photometric test?" Although the relative photometry method of testing luminaires is designed to normalize as many variables as possible, the efficiency that is calculated from the results of a relative photometric test is not a pure "optical efficiency". Consider the following:

- When the "bare lamps" are tested, they are tested in the ambient atmosphere of the lab 25°C(77°F).
- When the luminaire is tested, it is tested in the ambient atmosphere of the lab 25°C(77°F). The ambient temperature within the luminaire is guaranteed to be warmer than 25°C(77°F).

As it was stated earlier, the lumen output of the lamps will vary as a function of the ambient temperature. This means that the lumen output of the lamps when operated inside of the luminaire will be different from the lumen output of the lamps when they are tested for bare lamp output. The efficiency that is reported on a photometric test report is the ratio of the total luminous output of the luminaire to the total luminous output of the bare lamps. The only way that a test report can show the true "optical efficiency" of a luminaire is if the lamps produce the same amount of lumens in the luminaire as they did in the bare lamp test.

The point of this notice

Because the lumen output of the lamps operating within the luminaire can be different from the lumen output of the lamps operating outside of the luminaire, the luminaire efficiency can be increased/decreased beyond the "optical efficiency" of the luminaire. As an example, this situation could occur in a two lamp pendant T5 high output luminaire where mutual heating of the lamps, reflected radiant heat, contained heat, etc. can bring the temperature of the lamp close to the temperature that the lamp would operate at if it were in a 35°C(95°F) ambient temperature. Since T5 high output lamps have a peak lumen output near 35°C(95°F) ambient temperature, there is a possibility that an already high efficiency could be increased above 100%.

A Word of Caution

Although the efficiency shown in a relative photometric test report is not a pure "optical efficiency", this does not mean that there is a problem with the test procedure. It means that there is a temperature factor included into the test report based on an ambient temperature of 25°C(77°F). If you are using the test results in a situation where you know the ambient temperature will be significantly different from the 25°C(77°F) laboratory conditions, make sure that you use an appropriate temperature correction factor.

