



LUMINAIRE TESTING LABORATORY, INC.

SUSTAINING MEMBER of the IESNA

905 Harrison Street · Allentown, PA 18103 · 610-770-1044 · Fax 610-770-8912 · www.LuminaireTesting.com

LTL NUMBER: 13226 DATE: 11-05-2008
 PREPARED FOR: EB FLUORESCENT COMPANY, INC.
 CATALOG NUMBER: IN2/54C WHITE
 LUMINAIRE: FORMED WHITE ENAMEL STEEL HOUSING, FORMED WHITE ENAMEL STEEL REFLECTOR, NO ENCLOSURE.
 LAMPS: TWO 54 WATT HIGH OUTPUT T5 LINEAR FLUORESCENT LAMPS RATED AT 4400 LUMENS EACH.
 LAMP CATALOG NUMBER: PHILIPS F54T5/841/HO/ALTO
 BALLAST: ONE KEYSTONE TECHNOLOGIES KTEB-254HO-UV-TP-PS/LS
 MOUNTING: PENDANT

TOTAL INPUT WATTS =112.2 AT 120.0 VOLTS
 THE 0 DEGREE PLANE IS PARALLEL WITH THE LAMPS.

CANDELA DISTRIBUTION

	0.0	22.5	45.0	67.5	90.0
0	2061	2061	2061	2061	2061
5	2057	2057	2065	2076	2082
15	1987	2024	2072	2104	2118
25	1850	1931	2010	2034	2051
35	1653	1772	1844	1932	1976
45	1400	1548	1679	1839	1894
55	1102	1256	1502	1674	1740
65	762	992	1251	1430	1491
75	398	671	892	887	876
85	68	243	70	49	47
90	0	31	4	0	0
95	0	19	1	0	0
105	0	0	0	0	0
115	0	0	0	0	0
125	0	0	0	0	0
135	0	0	0	0	0
145	0	0	0	0	0
155	0	0	0	0	0
165	0	0	0	0	0
175	0	0	0	0	0
180	0	0	0	0	0

FLUX

198
584
915
1155
1297
1309
1186
804
142

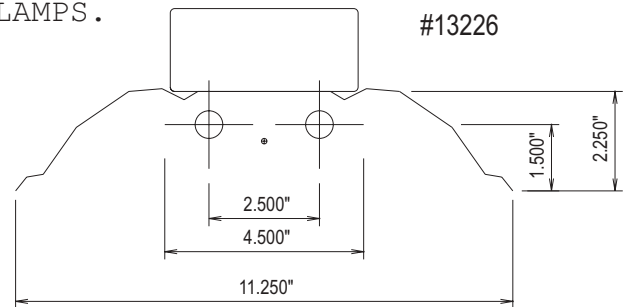

ZONAL LUMEN SUMMARY

ZONE	LUMENS	%LAMP	%FIXT
0- 30	1697	19.3	22.3
0- 40	2852	32.4	37.5
0- 60	5457	62.0	71.9
0- 90	7590	86.2	99.9
90-120	5	0.1	0.1
90-130	5	0.1	0.1
90-150	5	0.1	0.1
90-180	5	0.1	0.1
0-180	7595	86.3	100.0

TOTAL LUMINAIRE EFFICIENCY: 86.3%
 TOTAL REFLECTANCE OF PAINT: 84.1%
 CIE TYPE: DIRECT
 PLANE: 0-DEG 90-DEG
 SPACING CRITERIA: 1.3 1.5

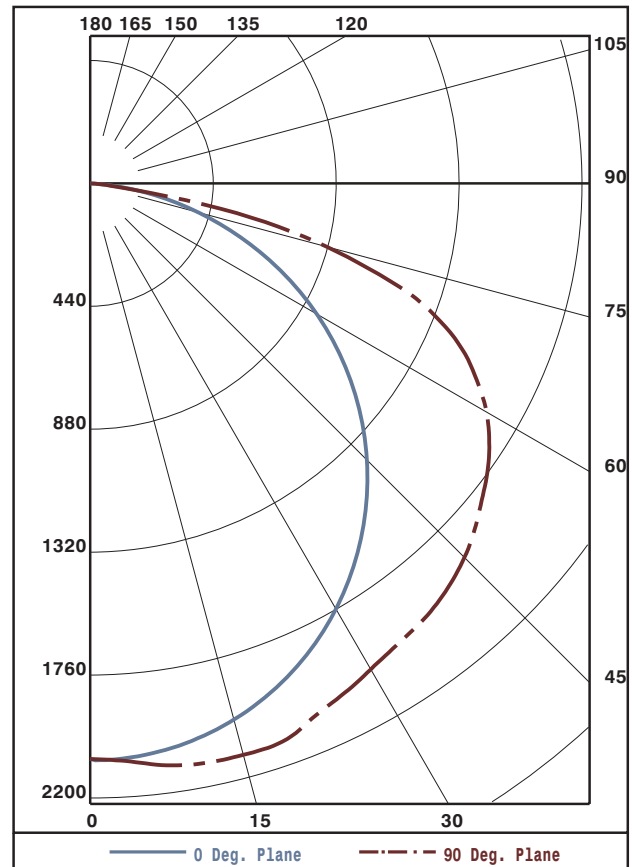

Approved By: MG



LUMINAIRE TESTING LABORATORY, INC.

SUSTAINING MEMBER of the IESNA

905 Harrison Street · Allentown, PA 18103 · 610-770-1044 · Fax 610-770-8912 · www.LuminaireTesting.com

LTL NUMBER: 13226

DATE: 11-05-2008

PREPARED FOR: EB FLUORESCENT COMPANY, INC.

COEFFICIENTS OF UTILIZATION - ZONAL CAVITY METHOD
EFFECTIVE FLOOR CAVITY REFLECTANCE 0.20

Table with 15 columns (RC, RW, and 14 numerical values) and 11 rows (0-10).

PLANE: 0-DEG 90-DEG
LUMINOUS LENGTH: 48.000 11.250
HEIGHT OF SIDE: 2.250 0.000

Table with 4 columns (ANGLE, AVERAGE, AVERAGE, AVERAGE) and 6 rows (0, 45, 55, 65, 75, 85).



LUMINAIRE TESTING LABORATORY, INC.

SUSTAINING MEMBER of the IESNA

905 Harrison Street · Allentown, PA 18103 · 610-770-1044 · Fax 610-770-8912 · www.LuminaireTesting.com

LTL NUMBER: 13226
PREPARED FOR: EB FLUORESCENT COMPANY, INC.

DATE: 11-05-2008

CANDELA DISTRIBUTION

Table with 6 columns of candela values for various angles from 0.0 to 180 degrees.

ZONAL LUMEN SUMMARY

Table with 2 columns: Zonal angle ranges and corresponding lumen values.

THIS TEST WAS CONDUCTED USING RELATIVE PHOTOMETRY TECHNIQUES ACCORDING TO STANDARD IESNA PROCEDURES. THE USER MUST THEREFORE USE CAUTION IN THE FOLLOWING SITUATIONS: 1) THIS TEST WAS PERFORMED USING A SPECIFIC BALLAST/LAMP COMBINATION. EXTRAPOLATION OF THESE DATA FOR OTHER BALLAST/LAMP COMBINATIONS MAY PRODUCE ERRONEOUS RESULTS. 2) ACCORDING TO IESNA PROCEDURES, THE BALLAST(S) AND LAMP(S) ARE PRESUMED TO PRODUCE 100% OF RATED OUTPUT. AN APPROPRIATE BALLAST FACTOR MUST BE APPLIED TO THE LUMEN OUTPUT RATINGS AND LUMINOUS INTENSITY VALUES GIVEN. 3) THIS TEST WAS CONDUCTED IN A CONTROLLED LABORATORY ENVIRONMENT WHERE THE AMBIENT TEMPERATURE WAS HELD AT 25°C ±1°C. FIELD PERFORMANCE MAY DIFFER PARTICULARLY IN REGARDS TO CHANGE IN LUMINOUS OUTPUT AS A RESULT OF DIFFERENCE IN AMBIENT TEMPERATURE AND METHOD OF MOUNTING THE LUMINAIRE.