



LUMINAIRE TESTING LABORATORY, INC.

SUSTAINING MEMBER of the IESNA

905 Harrison Street · Allentown, PA 18103 · 610-770-1044 · Fax 610-770-8912 · www.LuminaireTesting.com

LTL NUMBER: 13185

DATE: 06-19-2008

PREPARED FOR: EB FLUORESCENT COMPANY, INC.

CATALOG NUMBER: G1X4 4/32 C

LUMINAIRE: FORMED WHITE ENAMEL STEEL HOUSING/REFLECTOR, CLEAR PRISMATIC PLASTIC LENS.

LAMPS: FOUR 32 WATT T8 LINEAR FLUORESCENT LAMPS RATED AT 2850 LUMENS EACH.

LAMP CATALOG NUMBER: PHILIPS F32T8/TL841/ALTO

BALLAST: ONE ADVANCE ICN-4P32-SC

MOUNTING: RECESSED

TOTAL INPUT WATTS =103.3 AT 120.0 VOLTS

THE 0 DEGREE PLANE IS PARALLEL WITH THE LAMPS.

CANDELA DISTRIBUTION

	0.0	22.5	45.0	67.5	90.0
0	2700	2700	2700	2700	2700
5	2691	2687	2688	2694	2695
15	2590	2596	2612	2627	2632
25	2377	2395	2423	2447	2456
35	2048	2072	2105	2146	2156
45	1583	1568	1613	1613	1627
55	1012	1011	1015	976	966
65	545	515	474	491	480
75	287	286	252	302	322
85	111	113	101	129	120
90	0	0	0	0	0

FLUX

256
738
1116
1315
1233
892
503
302
120

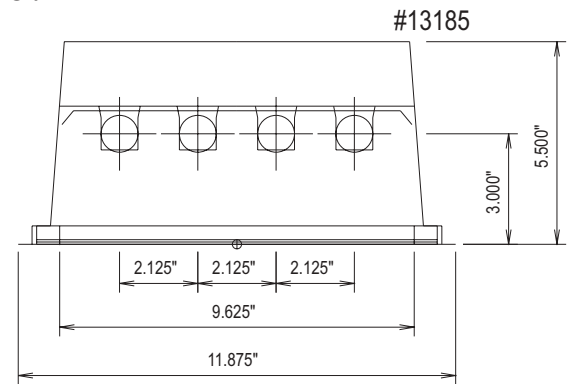

ZONAL LUMEN SUMMARY

ZONE	LUMENS	%LAMP	%FIXT
0- 30	2110	18.5	32.6
0- 40	3425	30.0	52.9
0- 60	5550	48.7	85.7
0- 90	6474	56.8	100.0
90-180	0	0.0	0.0
0-180	6474	56.8	100.0

TOTAL LUMINAIRE EFFICIENCY: 56.8%
 TOTAL REFLECTANCE OF PAINT: 82.2%
 CIE TYPE: DIRECT
 PLANE: 0-DEG 90-DEG
 SPACING CRITERIA: 1.2 1.3

LUMINOUS LENGTH: 45.625 9.625

LUMINANCE IN CANDELA PER SQUARE METER

ANGLE IN DEG	AVERAGE 0-DEG	AVERAGE 45-DEG	AVERAGE 90-DEG
0	9529.	9529.	9529.
45	7901.	8051.	8121.
55	6227.	6246.	5944.
65	4551.	3958.	4009.
75	3914.	3436.	4391.
85	4495.	4090.	4859.

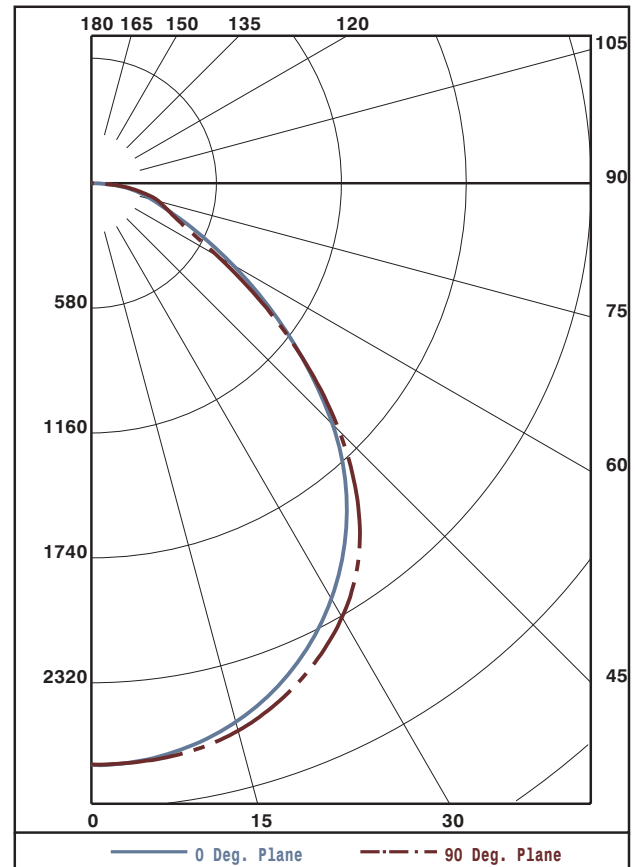

Approved By: MG



LUMINAIRE TESTING LABORATORY, INC.

SUSTAINING
MEMBER
of the
IESNA

905 Harrison Street · Allentown, PA 18103 · 610-770-1044 · Fax 610-770-8912 · www.LuminaireTesting.com

LTL NUMBER: 13185

DATE: 06-19-2008

PREPARED FOR: EB FLUORESCENT COMPANY, INC.

COEFFICIENTS OF UTILIZATION - ZONAL CAVITY METHOD EFFECTIVE FLOOR CAVITY REFLECTANCE 0.20

RC	80				70				50			30			10			0
RW	70	50	30	10	70	50	30	10	50	30	10	50	30	10	50	30	10	0
0	68	68	68	68	66	66	66	66	63	63	63	60	60	60	58	58	58	57
1	63	60	58	56	61	59	57	55	57	55	54	55	53	52	53	52	51	49
2	58	54	51	48	57	53	50	47	51	48	46	49	47	45	47	46	44	43
3	54	48	44	41	52	47	44	41	46	43	40	44	42	39	43	41	39	38
4	49	43	39	36	48	43	39	35	41	38	35	40	37	34	39	36	34	33
5	46	39	34	31	44	38	34	31	37	33	30	36	33	30	35	32	30	29
6	42	35	30	27	41	35	30	27	34	30	27	33	29	26	32	29	26	25
7	39	32	27	24	38	31	27	24	30	26	24	30	26	23	29	26	23	22
8	36	29	24	21	35	28	24	21	27	23	21	27	23	20	26	23	20	19
9	33	26	21	18	32	25	21	18	25	21	18	24	20	18	23	20	18	17
10	31	23	19	16	30	23	19	16	22	19	16	22	18	16	21	18	16	15

CANDELA DISTRIBUTION

	0.0	22.5	45.0	67.5	90.0
0	2700	2700	2700	2700	2700
5	2691	2687	2688	2694	2695
10	2653	2654	2662	2673	2676
15	2590	2596	2612	2627	2632
20	2498	2511	2533	2551	2557
25	2377	2395	2423	2447	2456
30	2227	2250	2282	2314	2327
35	2048	2072	2105	2146	2156
40	1838	1847	1885	1913	1921
45	1583	1568	1613	1613	1627
50	1291	1287	1324	1297	1298
55	1012	1011	1015	976	966
60	757	736	704	686	676
65	545	515	474	491	480
70	391	372	322	383	384
75	287	286	252	302	322
80	213	198	196	218	232
85	111	113	101	129	120
90	0	0	0	0	0

ZONAL LUMEN SUMMARY

0- 5	64.
5- 10	192.
10- 15	313.
15- 20	424.
20- 25	520.
25- 30	596.
30- 35	647.
35- 40	668.
40- 45	647.
45- 50	586.
50- 55	500.
55- 60	392.
60- 65	289.
65- 70	214.
70- 75	169.
75- 80	133.
80- 85	90.
85- 90	30.

THIS TEST WAS CONDUCTED USING RELATIVE PHOTOMETRY TECHNIQUES ACCORDING TO STANDARD IESNA PROCEDURES. THE USER MUST THEREFORE USE CAUTION IN THE FOLLOWING SITUATIONS: 1) THIS TEST WAS PERFORMED USING A SPECIFIC BALLAST/LAMP COMBINATION. EXTRAPOLATION OF THESE DATA FOR OTHER BALLAST/LAMP COMBINATIONS MAY PRODUCE ERRONEOUS RESULTS. 2) ACCORDING TO IESNA PROCEDURES, THE BALLAST(S) AND LAMP(S) ARE PRESUMED TO PRODUCE 100% OF RATED OUTPUT. AN APPROPRIATE BALLAST FACTOR MUST BE APPLIED TO THE LUMEN OUTPUT RATINGS AND LUMINOUS INTENSITY VALUES GIVEN. 3) THIS TEST WAS CONDUCTED IN A CONTROLLED LABORATORY ENVIRONMENT WHERE THE AMBIENT TEMPERATURE WAS HELD AT 25°C ±1°C. FIELD PERFORMANCE MAY DIFFER PARTICULARLY IN REGARDS TO CHANGE IN LUMINOUS OUTPUT AS A RESULT OF DIFFERENCE IN AMBIENT TEMPERATURE AND METHOD OF MOUNTING THE LUMINAIRE.