



# LUMINAIRE TESTING LABORATORY, INC.

SUSTAINING  
MEMBER  
of the  
IESNA

905 Harrison Street · Allentown, PA 18103 · 610-770-1044 · Fax 610-770-8912 · www.LuminaireTesting.com

LTL NUMBER: 13206 DATE: 08-12-2008  
 PREPARED FOR: EB FLUORESCENT COMPANY, INC.  
 CATALOG NUMBER: CT 2/32  
 LUMINAIRE: MOLDED PLASTIC HOUSING, FORMED WHITE ENAMEL STEEL REFLECTOR,  
 CLEAR LINEAR PRISMATIC PLASTIC LENS.  
 LAMPS: TWO 32 WATT T8 LINEAR FLUORESCENT LAMPS RATED AT 2850 LUMENS  
 EACH.  
 LAMP CATALOG NUMBER: PHILIPS F32T8/TL841/ALTO  
 BALLAST: ONE UNIVERSAL LIGHTING TECHNOLOGIES B232IUNVHP-B  
 MOUNTING: SURFACE/PENDANT

TOTAL INPUT WATTS = 53.0 AT 120.0 VOLTS  
 THE 0 DEGREE PLANE IS PARALLEL WITH THE LAMPS.

#13206

### CANDELA DISTRIBUTION

	0.0	22.5	45.0	67.5	90.0
0	931	931	931	931	931
5	924	936	946	953	956
15	889	924	956	988	1001
25	824	873	953	1004	1024
35	725	791	913	1041	1091
45	599	694	902	950	953
55	446	591	713	742	757
65	280	431	501	583	629
75	119	227	377	485	528
85	20	123	254	368	411
90	5	79	198	314	357
95	6	53	174	276	307
105	5	20	95	166	192
115	1	1	40	76	89
125	0	0	3	29	39
135	0	0	0	0	3
145	0	0	0	0	0
155	0	0	0	0	0
165	0	0	0	0	0
175	0	0	0	0	0
180	0	0	0	0	0

### FLUX

90
270
435
574
640
593
490
374
263
179
101
41
12
1
0
0
0
0
0
0
0
0

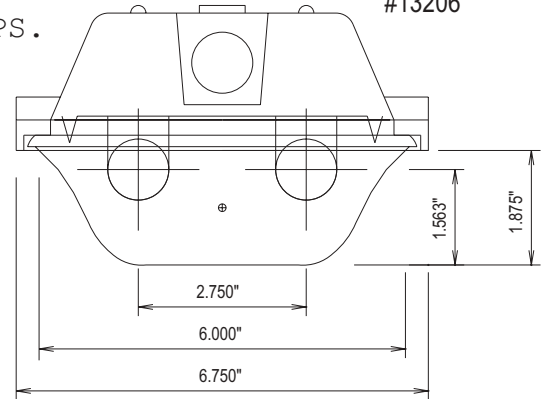

### ZONAL LUMEN SUMMARY

ZONE	LUMENS	%LAMP	%FIXT
0- 30	795	14.0	19.6
0- 40	1369	24.0	33.7
0- 60	2602	45.6	64.1
0- 90	3728	65.4	91.8
90-120	321	5.6	7.9
90-130	333	5.8	8.2
90-150	334	5.9	8.2
90-180	334	5.9	8.2
0-180	4062	71.3	100.0

TOTAL LUMINAIRE EFFICIENCY: 71.3%  
 TOTAL REFLECTANCE OF PAINT: 87.0%  
 CIE TYPE: DIRECT  
 PLANE: 0-DEG 90-DEG  
 SPACING CRITERIA: 1.2 1.7

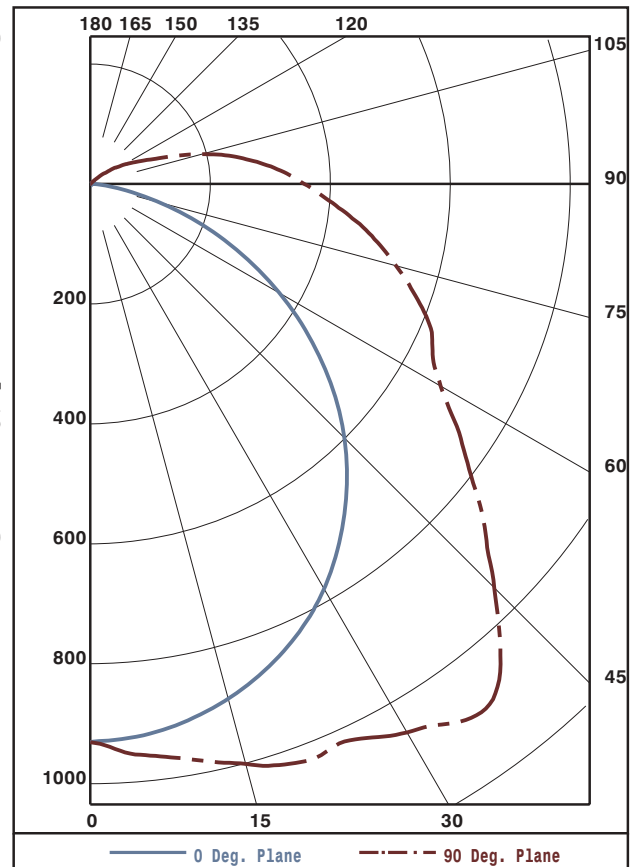

Approved By: MG



LUMINAIRE TESTING LABORATORY, INC.

SUSTAINING MEMBER of the IESNA

905 Harrison Street · Allentown, PA 18103 · 610-770-1044 · Fax 610-770-8912 · www.LuminaireTesting.com

LTL NUMBER: 13206

DATE: 08-12-2008

PREPARED FOR: EB FLUORESCENT COMPANY, INC.

COEFFICIENTS OF UTILIZATION - ZONAL CAVITY METHOD
EFFECTIVE FLOOR CAVITY REFLECTANCE 0.20

Table with 18 columns (RC, RW, and 16 numerical values) and 11 rows (0-10).

PLANE: 0-DEG 90-DEG
LUMINOUS LENGTH: 50.250 6.000
HEIGHT OF SIDE: 1.875 1.875

Table with 4 columns (ANGLE IN DEG, AVERAGE 0-DEG, AVERAGE 45-DEG, AVERAGE 90-DEG) and 6 rows (0, 45, 55, 65, 75, 85).



LUMINAIRE TESTING LABORATORY, INC.

SUSTAINING MEMBER of the IESNA

905 Harrison Street · Allentown, PA 18103 · 610-770-1044 · Fax 610-770-8912 · www.LuminaireTesting.com

LTL NUMBER: 13206
PREPARED FOR: EB FLUORESCENT COMPANY, INC.

DATE: 08-12-2008

CANDELA DISTRIBUTION

Table with 6 columns representing candela values at various angles (0.0, 22.5, 45.0, 67.5, 90.0) for angles from 0 to 180 degrees.

ZONAL LUMEN SUMMARY

Table with 2 columns representing lumen values for various zones (0-5, 5-10, etc.) up to 175-180 degrees.

THIS TEST WAS CONDUCTED USING RELATIVE PHOTOMETRY TECHNIQUES ACCORDING TO STANDARD IESNA PROCEDURES. THE USER MUST THEREFORE USE CAUTION IN THE FOLLOWING SITUATIONS: 1) THIS TEST WAS PERFORMED USING A SPECIFIC BALLAST/LAMP COMBINATION. EXTRAPOLATION OF THESE DATA FOR OTHER BALLAST/LAMP COMBINATIONS MAY PRODUCE ERRONEOUS RESULTS. 2) ACCORDING TO IESNA PROCEDURES, THE BALLAST(S) AND LAMP(S) ARE PRESUMED TO PRODUCE 100% OF RATED OUTPUT. AN APPROPRIATE BALLAST FACTOR MUST BE APPLIED TO THE LUMEN OUTPUT RATINGS AND LUMINOUS INTENSITY VALUES GIVEN. 3) THIS TEST WAS CONDUCTED IN A CONTROLLED LABORATORY ENVIRONMENT WHERE THE AMBIENT TEMPERATURE WAS HELD AT 25°C ±1°C. FIELD PERFORMANCE MAY DIFFER PARTICULARLY IN REGARDS TO CHANGE IN LUMINOUS OUTPUT AS A RESULT OF DIFFERENCE IN AMBIENT TEMPERATURE AND METHOD OF MOUNTING THE LUMINAIRE.