



# LUMINAIRE TESTING LABORATORY, INC.

SUSTAINING  
MEMBER  
of the  
IESNA

905 Harrison Street · Allentown, PA 18103 · 610-770-1044 · Fax 610-770-8912 · www.LuminaireTesting.com

LTL NUMBER: 13195

DATE: 09-12-2008

PREPARED FOR: EB FLUORESCENT COMPANY, INC.

CATALOG NUMBER: CH 2/54

LUMINAIRE: FORMED WHITE ENAMEL STEEL HOUSING/REFLECTOR, NO ENCLOSURE.

LAMPS: TWO 54 WATT T5 HIGH OUTPUT LINEAR FLUORESCENT LAMPS RATED AT 4400 LUMENS EACH.

LAMP CATALOG NUMBER: PHILIPS F54T5/841/HO/ALTO

BALLAST: ONE KEYSTONE TECHNOLOGIES KTEB-254HO-UV-TP-PS/LS

MOUNTING: SURFACE/PENDANT

TOTAL INPUT WATTS =120.9 AT 120.0 VOLTS

THE 0 DEGREE PLANE IS PARALLEL WITH THE LAMPS.

#13195

| CANDELA DISTRIBUTION |      |      |      |      |      | FLUX |
|----------------------|------|------|------|------|------|------|
| 0.0                  | 22.5 | 45.0 | 67.5 | 90.0 |      |      |
| 0                    | 1742 | 1742 | 1742 | 1742 | 1742 |      |
| 5                    | 1726 | 1737 | 1740 | 1749 | 1753 | 166  |
| 15                   | 1664 | 1691 | 1723 | 1761 | 1778 | 488  |
| 25                   | 1542 | 1595 | 1683 | 1749 | 1774 | 772  |
| 35                   | 1367 | 1459 | 1587 | 1712 | 1761 | 991  |
| 45                   | 1145 | 1279 | 1480 | 1663 | 1730 | 1132 |
| 55                   | 884  | 1065 | 1351 | 1551 | 1624 | 1168 |
| 65                   | 596  | 849  | 1150 | 1433 | 1527 | 1114 |
| 75                   | 299  | 582  | 998  | 1260 | 1361 | 973  |
| 85                   | 49   | 370  | 619  | 787  | 848  | 607  |
| 90                   | 0    | 178  | 392  | 560  | 620  |      |
| 95                   | 0    | 287  | 589  | 762  | 821  | 538  |
| 105                  | 0    | 197  | 401  | 784  | 944  | 497  |
| 115                  | 0    | 91   | 425  | 556  | 605  | 338  |
| 125                  | 0    | 0    | 283  | 525  | 599  | 246  |
| 135                  | 0    | 0    | 98   | 295  | 370  | 113  |
| 145                  | 0    | 0    | 0    | 66   | 117  | 21   |
| 155                  | 0    | 0    | 0    | 0    | 0    | 0    |
| 165                  | 0    | 0    | 0    | 0    | 0    | 0    |
| 175                  | 0    | 0    | 0    | 0    | 0    | 0    |
| 180                  | 0    | 0    | 0    | 0    | 0    | 0    |

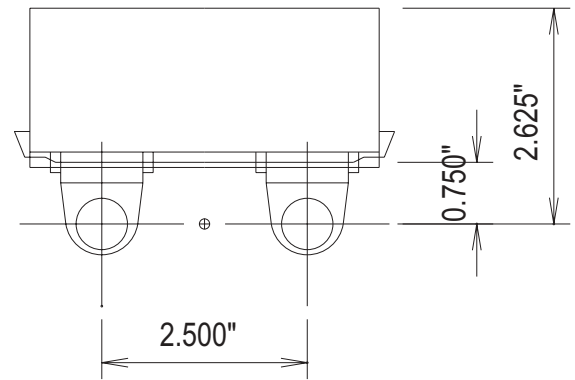

| ZONAL LUMEN SUMMARY |        |       |       |  |
|---------------------|--------|-------|-------|--|
| ZONE                | LUMENS | %LAMP | %FIXT |  |
| 0- 30               | 1426   | 16.2  | 15.6  |  |
| 0- 40               | 2418   | 27.5  | 26.4  |  |
| 0- 60               | 4719   | 53.6  | 51.5  |  |
| 0- 90               | 7413   | 84.2  | 80.9  |  |
| 90-120              | 1374   | 15.6  | 15.0  |  |
| 90-130              | 1621   | 18.4  | 17.7  |  |
| 90-150              | 1755   | 19.9  | 19.1  |  |
| 90-180              | 1755   | 19.9  | 19.1  |  |
| 0-180               | 9168   | 104.2 | 100.0 |  |

TOTAL LUMINAIRE EFFICIENCY: 104.2%  
 TOTAL REFLECTANCE OF PAINT: 81.6%  
 CIE TYPE: SEMI-DIRECT  
 PLANE: 0-DEG 90-DEG  
 SPACING CRITERIA: 1.2 1.5

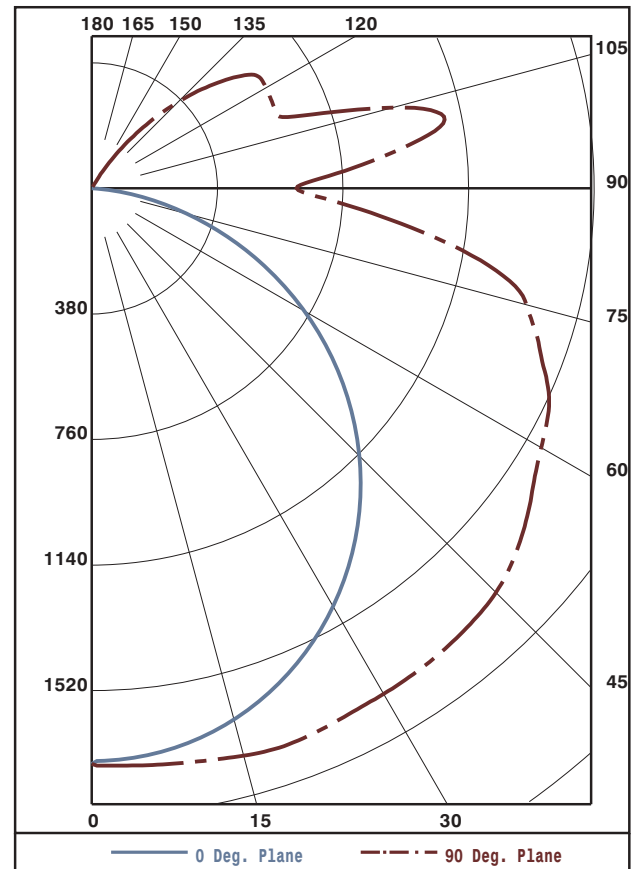

Approved By: MG



LUMINAIRE TESTING LABORATORY, INC.

SUSTAINING MEMBER of the IESNA

905 Harrison Street · Allentown, PA 18103 · 610-770-1044 · Fax 610-770-8912 · www.LuminaireTesting.com

LTL NUMBER: 13195

DATE: 09-12-2008

PREPARED FOR: EB FLUORESCENT COMPANY, INC.

COEFFICIENTS OF UTILIZATION - ZONAL CAVITY METHOD
EFFECTIVE FLOOR CAVITY REFLECTANCE 0.20

Table with 10 rows (RC/RW 0-10) and 14 columns representing different room cavity ratios (80, 70, 50, 30, 10, 0).

PLANE: 0-DEG 90-DEG
LUMINOUS LENGTH: 48.000 4.500
HEIGHT OF SIDE: 1.125 1.125

Table with 4 columns: ANGLE IN DEG, AVERAGE 0-DEG, AVERAGE 45-DEG, AVERAGE 90-DEG. Rows for angles 0, 45, 55, 65, 75, 85.



LUMINAIRE TESTING LABORATORY, INC.

SUSTAINING MEMBER of the IESNA

905 Harrison Street · Allentown, PA 18103 · 610-770-1044 · Fax 610-770-8912 · www.LuminaireTesting.com

LTL NUMBER: 13195
PREPARED FOR: EB FLUORESCENT COMPANY, INC.

DATE: 09-12-2008

CANDELA DISTRIBUTION

Table with 6 columns representing candela values at various angles (0.0, 22.5, 45.0, 67.5, 90.0) for angles from 0 to 180 degrees.

ZONAL LUMEN SUMMARY

Table with 2 columns representing lumen values for various zones (0-5, 5-10, etc.) up to 175-180 degrees.

THIS TEST WAS CONDUCTED USING RELATIVE PHOTOMETRY TECHNIQUES ACCORDING TO STANDARD IESNA PROCEDURES. THE USER MUST THEREFORE USE CAUTION IN THE FOLLOWING SITUATIONS: 1) THIS TEST WAS PERFORMED USING A SPECIFIC BALLAST/LAMP COMBINATION. EXTRAPOLATION OF THESE DATA FOR OTHER BALLAST/LAMP COMBINATIONS MAY PRODUCE ERRONEOUS RESULTS. 2) ACCORDING TO IESNA PROCEDURES, THE BALLAST(S) AND LAMP(S) ARE PRESUMED TO PRODUCE 100% OF RATED OUTPUT. AN APPROPRIATE BALLAST FACTOR MUST BE APPLIED TO THE LUMEN OUTPUT RATINGS AND LUMINOUS INTENSITY VALUES GIVEN. 3) THIS TEST WAS CONDUCTED IN A CONTROLLED LABORATORY ENVIRONMENT WHERE THE AMBIENT TEMPERATURE WAS HELD AT 25°C ±1°C. FIELD PERFORMANCE MAY DIFFER PARTICULARLY IN REGARDS TO CHANGE IN LUMINOUS OUTPUT AS A RESULT OF DIFFERENCE IN AMBIENT TEMPERATURE AND METHOD OF MOUNTING THE LUMINAIRE.



## A Notice About Extremely High Efficiencies and Efficiencies Exceeding 100%

### Preface

All fluorescent lamps exhibit some change in lumen output as a function of ambient temperature. Highly loaded lamps such as T5 high output, twin tube fluorescent, and high-wattage compact fluorescent lamps typically exhibit the most dramatic light output versus temperature curves. These curves are non-linear functions that have a peak light output at a temperature near the middle of the lamp’s usable temperature range. See Figure 1 for the temperature response of a typical T5 high output lamp. The specific temperature where the peak lumen output occurs is dependent on many variables within the lamp manufacturing process as well as the lamp orientation within the luminaire (base up, base down, horizontal).

In the case of T5 high output lamps, the peak lumen output temperature falls near the 35°C(95°F) temperature.

### What does this have to do with testing?

You might be wondering, “Since IESNA standards on fluorescent testing are based on relative photometry, what effect does this have on my photometric test?” Although the relative photometry method of testing luminaires is designed to normalize as many variables as possible, the efficiency that is calculated from the results of a relative photometric test is not a pure “optical efficiency”. Consider the following:

- When the “bare lamps” are tested, they are tested in the ambient atmosphere of the lab 25°C(77°F).
- When the luminaire is tested, it is tested in the ambient atmosphere of the lab 25°C(77°F). The ambient temperature within the luminaire is guaranteed to be warmer than 25°C(77°F).

As it was stated earlier, the lumen output of the lamps will vary as a function of the ambient temperature. This means that the lumen output of the lamps when operated inside of the luminaire will be different from the lumen output of the lamps when they are tested for bare lamp output. The efficiency that is reported on a photometric test report is the ratio of the total luminous output of the luminaire to the total luminous output of the bare lamps. The only way that a test report can show the true “optical efficiency” of a luminaire is if the lamps produce the same amount of lumens in the luminaire as they did in the bare lamp test.

### The point of this notice

Because the lumen output of the lamps operating within the luminaire can be different from the lumen output of the lamps operating outside of the luminaire, the luminaire efficiency can be increased/decreased beyond the “optical efficiency” of the luminaire. As an example, this situation could occur in a two lamp pendant T5 high output luminaire where mutual heating of the lamps, reflected radiant heat, contained heat, etc. can bring the temperature of the lamp close to the temperature that the lamp would operate at if it were in a 35°C(95°F) ambient temperature. Since T5 high output lamps have a peak lumen output near 35°C(95°F) ambient temperature, there is a possibility that an already high efficiency could be increased above 100%.

### A Word of Caution

Although the efficiency shown in a relative photometric test report is not a pure “optical efficiency”, this does not mean that there is a problem with the test procedure. It means that there is a temperature factor included into the test report based on an ambient temperature of 25°C(77°F). If you are using the test results in a situation where you know the ambient temperature will be significantly different from the 25°C(77°F) laboratory conditions, make sure that you use an appropriate temperature correction factor.

